

Section 9.1

1. x-intercept = (2,0), y-intercept=(0,4)

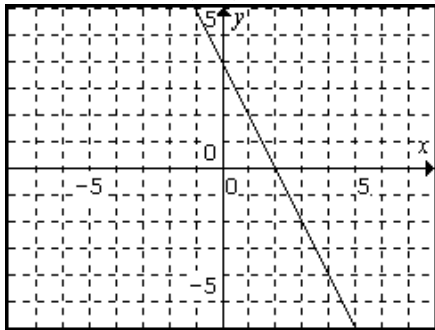

3. x-intercept = (0,0), y-intercept = (0,0)

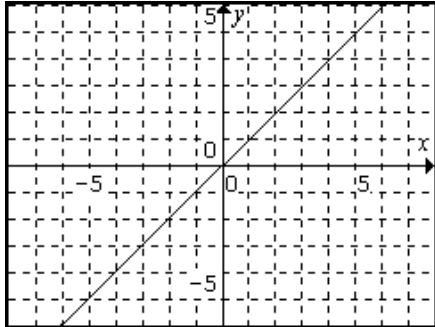

5. x-intercept = $(\frac{1}{2}, 0)$, y-intercept = (0,-2)

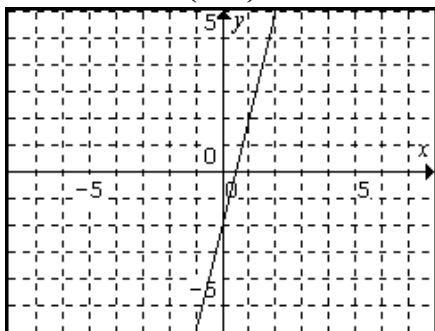

7. x-intercept = (-14,0), y-intercept = (0,-2)

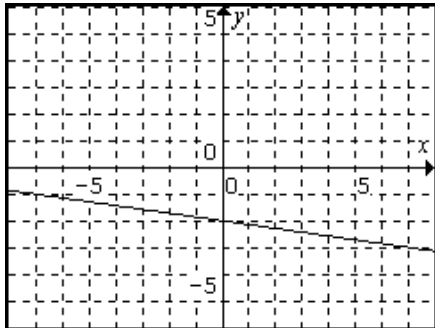

17. $m = 2$

19. $m = 1$

23. $m = \text{undefined}$

25. $m = \frac{1}{4}$

9. x-intercept = $(\frac{1}{4}, 0)$, y-intercept = $(0, -\frac{1}{2})$

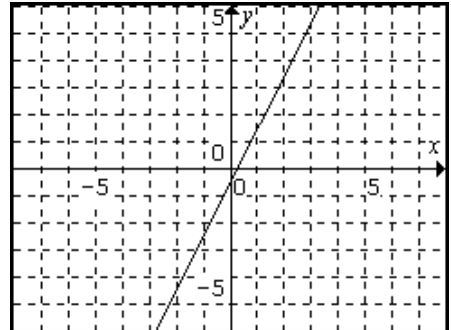

11. x-intercept = (-8,0), y-intercept = (0,4)

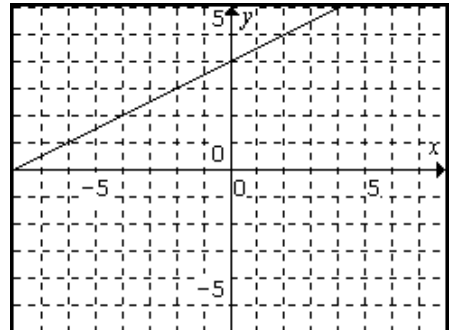

13. x-intercept = (8,0), y-intercept = (0,12)

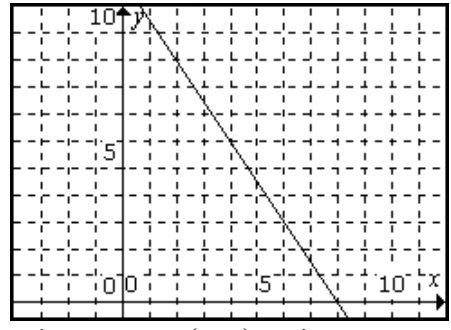

15. x-intercept = $(\frac{21}{8}, 0)$, y-intercept = $(0, -\frac{21}{2})$

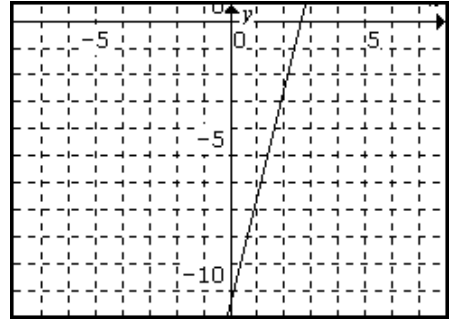

21. $m = -\frac{1}{5}$

27. $m = \frac{49}{78}$

29. $m = -3$

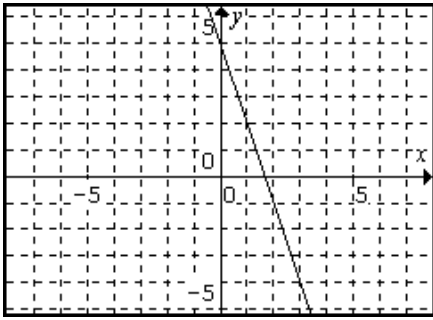

31. $m = \frac{1}{2}$

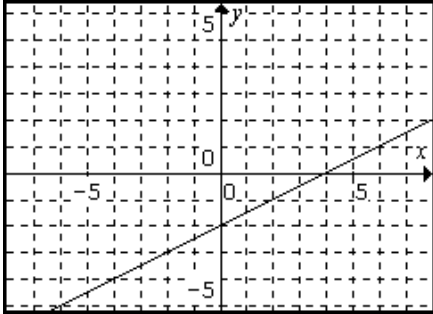

33. $m = -\frac{2}{3}$

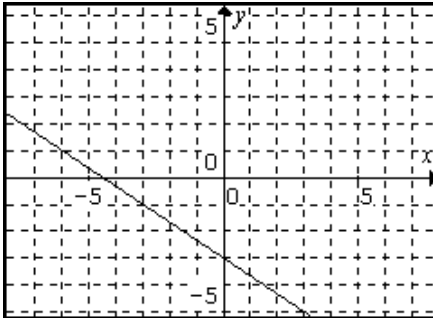

35. $m = \frac{7}{5}$

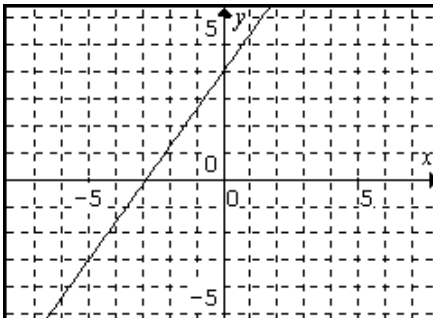

37. $m = -\frac{1}{3}$

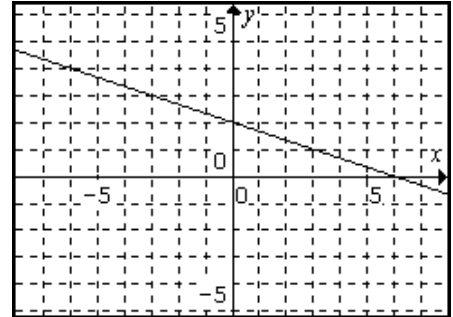

39. $m = -\frac{2}{3}$

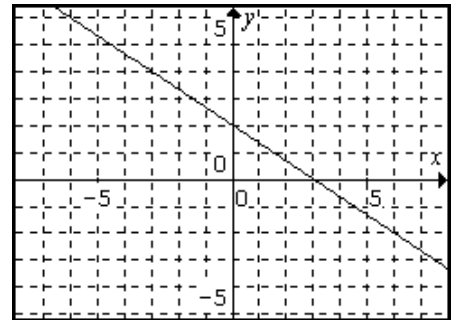

41. $m = \frac{5}{4}$

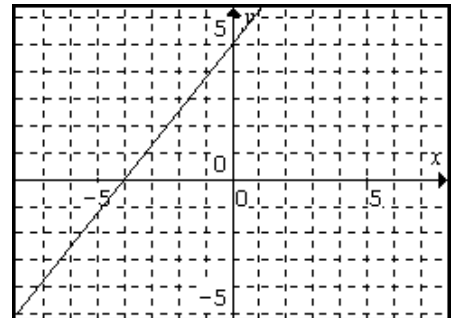

43. $m = -2$

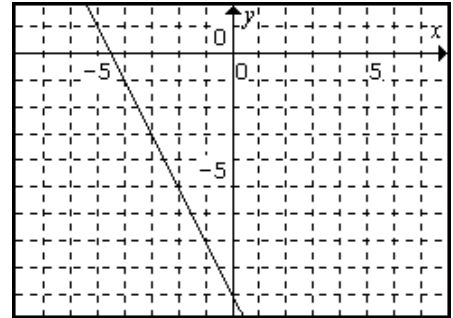

45. $y = -2x + 5$

47. $y = \frac{2}{3}x - \frac{7}{3}$

49. $y = -\frac{3}{5}x - \frac{16}{5}$

51. $y = 7x - 23$

53. $y = -\frac{19}{9}x + \frac{13}{9}$

55. $y = -\frac{2}{3}x - \frac{1}{3}$

57. $5x - y = 22$

59. $x + 3y = -29$

61. $x + 3y = -21$

63. $6x + 7y = 9$

65. $9x - 2y = -78$

67. $2x + 3y = -1$

69. $y = \frac{1}{4}x - 1, x - 4y = 4$

71. $y = -\frac{1}{2}x + \frac{3}{2}, x + 2y = 3$

73. $y = -\frac{1}{3}x + 2, x + 3y = 6$

75. $y = -3x, 3x + y = 0$

77. $y = -\frac{5}{2}x + 10, 5x + 2y = 20$

Section 9.2

1. a. Function $D: \{2,0,6,3,4\}$ $R: \{1,0,5,2,-1\}$
 b. Not a Function $D: \{1,2,-3\}$ $R: \{1,0,7\}$
 c. Function $D: \{a,e,i,o,u\}$ $R: \{A,E,I,O,U\}$
 d. Function $D: \{x_1,x_2,x_3,x_4\}$ $R: \{y_1,y_2\}$
3. a. Yes b. Yes c. No d. Yes
5. Yes 7. Yes 9. Yes 11. Yes 13. Yes
15. a. -1 b. 2 c. -4 d. -7 17. a. 0 b. 10 c. 0 d. 1
19. a. 3 b. 3 c. 5 d. $|2a-3|$ 21. a. -1 b. $\frac{1}{2}$ c. 1 d. $\frac{2t-1}{t+1}$
23. a. 1 b. 2 c. $\sqrt{4n+1}$ d. $\sqrt{4a+4b+1}$ 25. a. 1 b. -3 c. $2t-|t|$ d. $2t-4-|t-2|$
27. a. 0 b. $\sqrt{2(\text{apple})-1}$ c. $\sqrt{2a+1}$ 29. a. 5 b. $2-3u$ c. $-3x-1$ d. -3
31. a. $3t^2-t$ b. $3t^2+5t+2$ c. $3t^4+12t^3+11t^2-2t$ d. $6x+3k-1$
33. a. $2x^2+3x+1$ b. $8x^2-14x+6$ c. $2x+5-3\sqrt{x+2}$ d. $4x+2h-3$
35. a. $a\Delta^2+b\Delta+c$
 b. $a\Delta^2+2a\Delta+a+b\Delta+b+c$
 c. $4a\Delta^2+4a\Delta\Theta+a\Theta^2+2b\Delta+b\Theta+c$
 d. $2ax+ah+b$
37. a. x^2 b. $\frac{1}{n^2-2nm+m^2}$ c. $\frac{1}{t^4-2t^3+t^2}$ d. $\frac{-2x-h}{x^2(x+h)^2}$
39. a. $\frac{x^2}{x^2+1}$ b. $\frac{n-1}{n}$ c. x d. $\frac{1}{(x+h+1)(x+1)}$
41. a. x b. $(x+k)^3 = x^3+3xk^2+3x^2k+k^3$ c. $3x^2+3xk+k^2$
43. a. 0 b. $x^3+3x^2h+3xh^2+h^3-2x^2-4xh-2h^2-2x-2h+1$ c. $3x^2+3xh+h^2-4x-2h-2$

Section 9.3

1. $D: (-\infty, \infty)$
 $R: (-\infty, \infty)$
3. $D: (-\infty, \infty)$
 $R: (-\infty, \infty)$

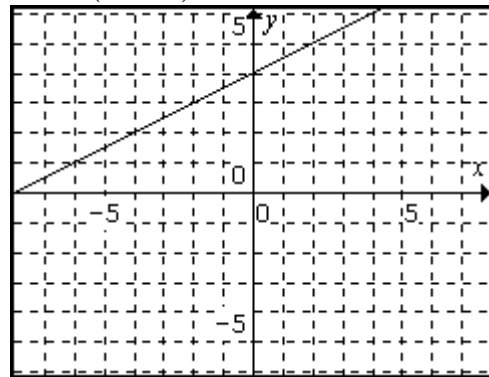
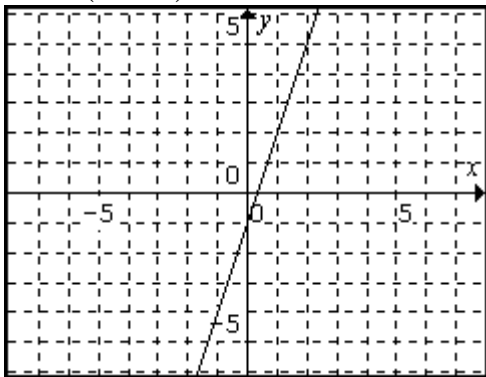

5. $D: [0, \infty)$

$R: [0, \infty)$

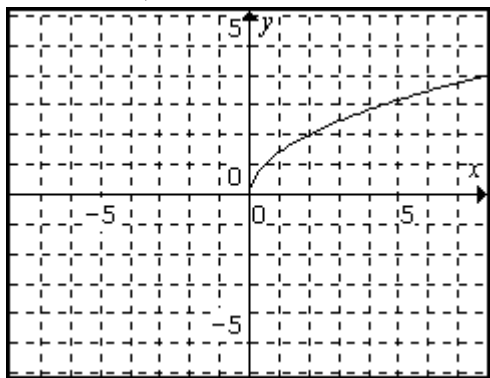

7. $D: (-\infty, \infty)$

$R: (-\infty, \infty)$

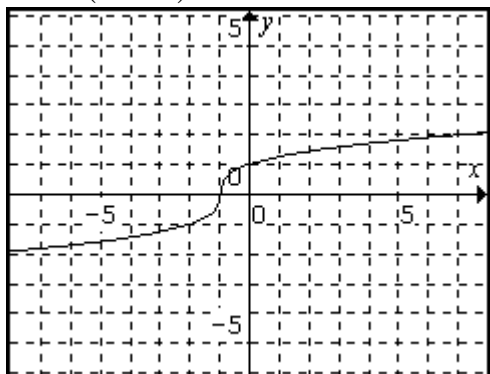

9. $D: (-\infty, \infty)$

$R: [0, \infty)$

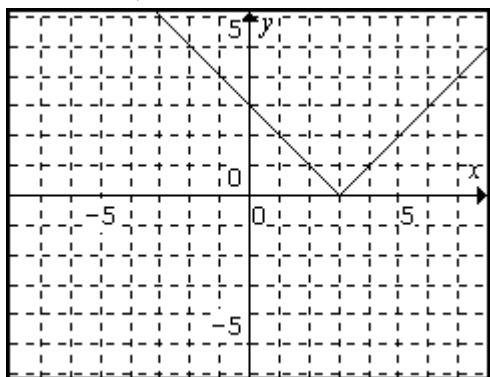

11. $D: (-\infty, \infty)$

$R: [-2, \infty)$

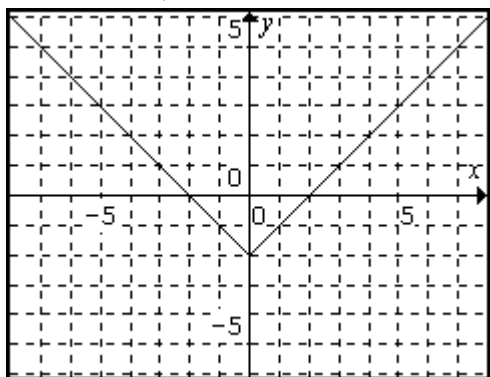

13. $D: (-\infty, \infty)$

$R: [2, \infty)$

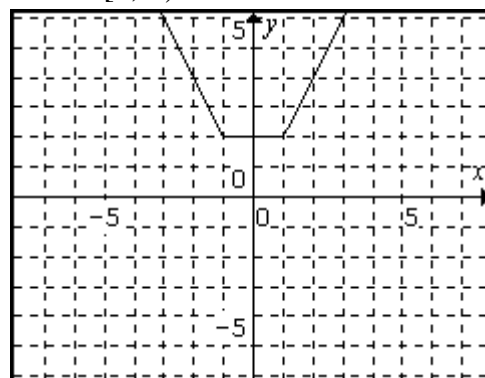

15. $D: (-\infty, \infty)$

$R: [0, \infty)$

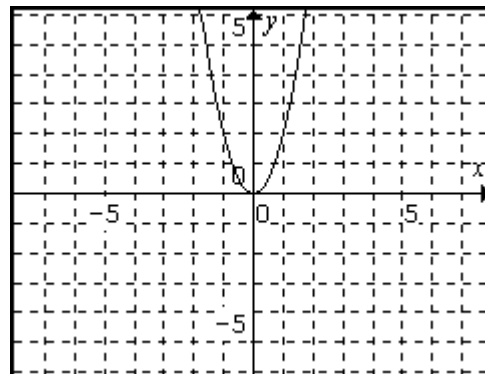

17. $D: (-\infty, \infty)$

$R: (-\infty, \infty)$

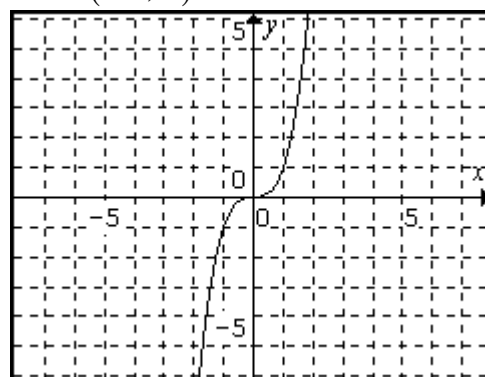

19. $D: (-\infty, \infty)$

$R: [0, \infty)$

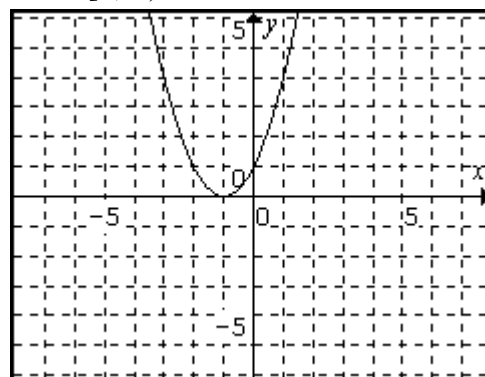

21. $D: (-\infty, \infty)$

$R: \left[-\frac{2187}{256}, \infty\right)$

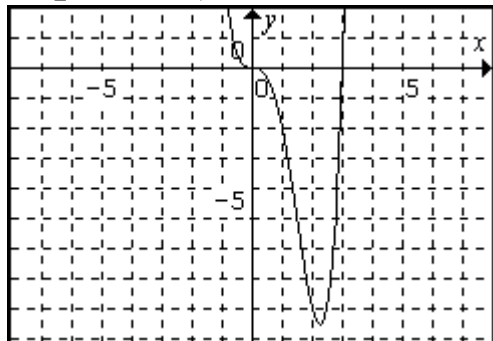

23. $D: (-\infty, \infty)$

$R: [0, \infty)$

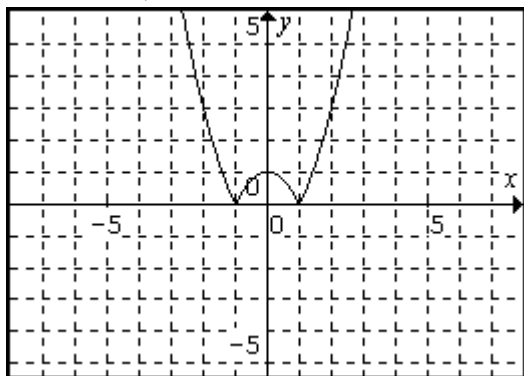

25. $D: (-\infty, 0) \cup (0, \infty)$

$R: (-\infty, 0) \cup (0, \infty)$

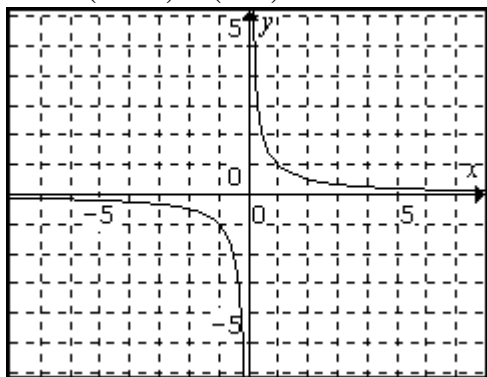

27. $D: (-\infty, \infty)$

$R: [0, \infty)$

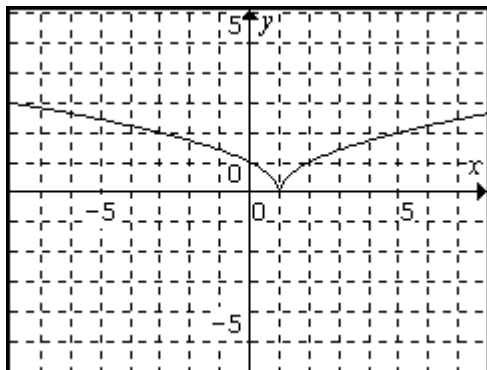

29. $D: (-\infty, 0]$

$R: (-\infty, 2]$

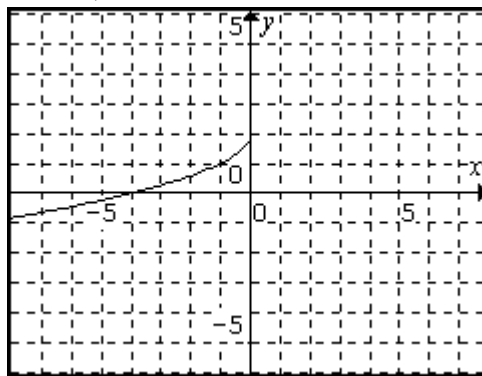

31. a.

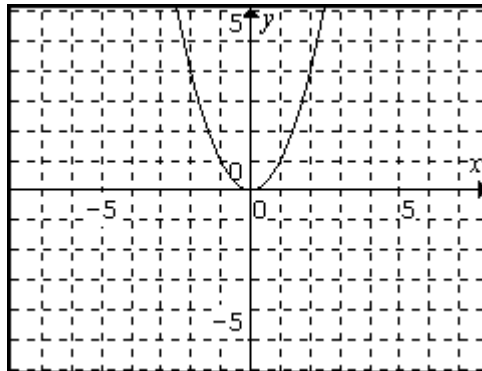

b.

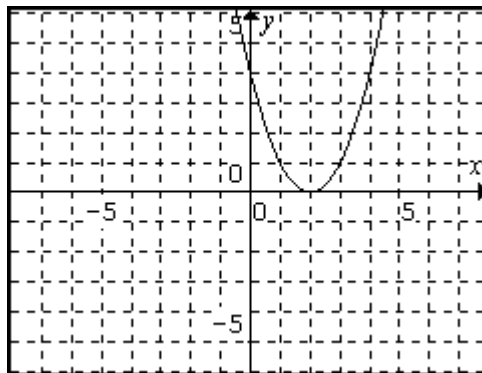

c.

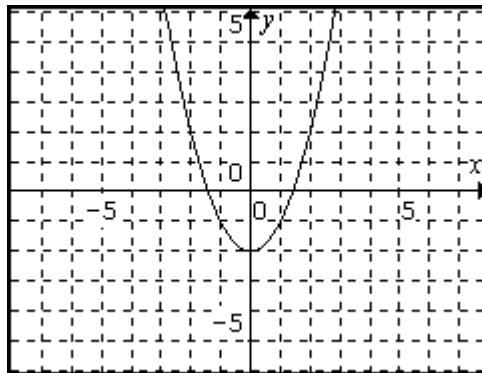

d.

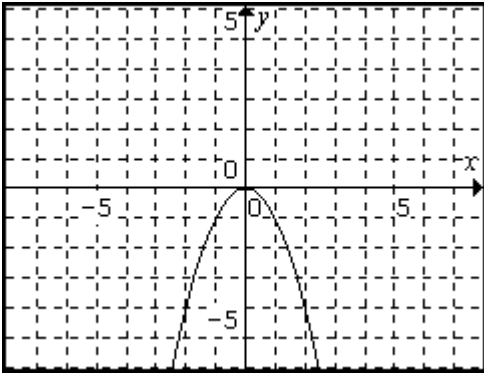

f.

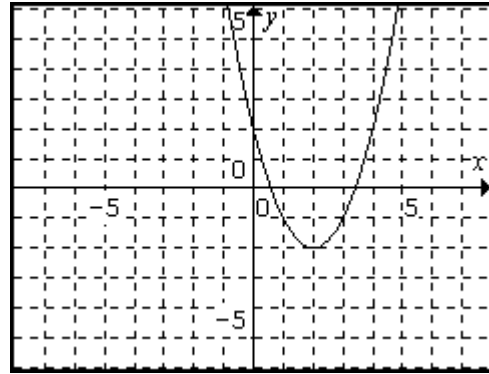

e.

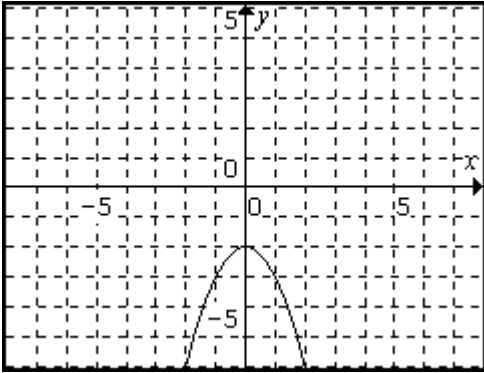

33. yes

35. yes

37. No

39. No

41. $D: \left[\frac{1}{2}, \infty\right)$

43. $D: (-\infty, \infty)$

45. $D: (-\infty, \infty)$

47. $D: (-\infty, -2) \cup (-2, 0) \cup (0, \infty)$

49. $D: [-4, \infty)$

51. $D: (-\infty, 2]$

53. $D: \left(-\infty, \frac{5}{2}\right]$

55. $D: (-\infty, 4) \cup (4, \infty)$

57. $D: (-\infty, -2) \cup (-2, 2) \cup (2, \infty)$

59. $D: (-\infty, 0]$

61. $D: \left[-\frac{1}{2}, 1\right) \cup (1, \infty)$

63. $D: (-1, \infty)$

Section 9.4

1.

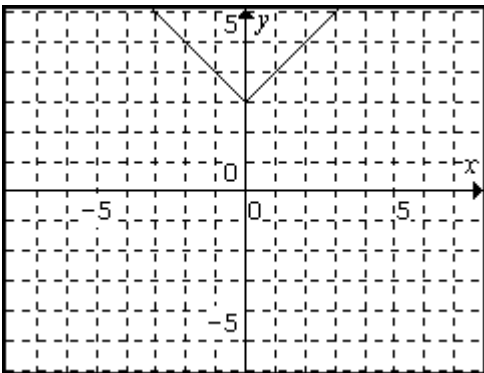

shift up 3 units

3.

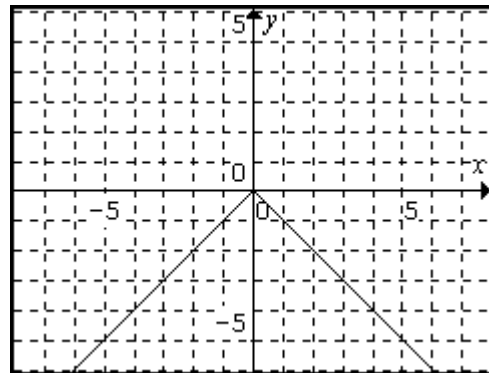

reflection about x-axis

5.

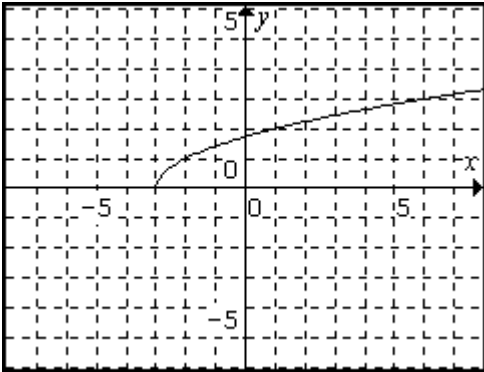

Shift left 3 units

7.

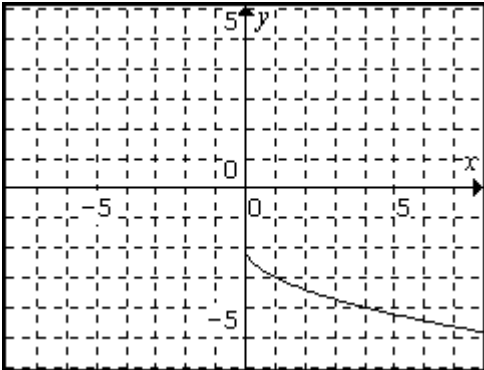

Reflection about x-axis

Shift down 2 units

9.

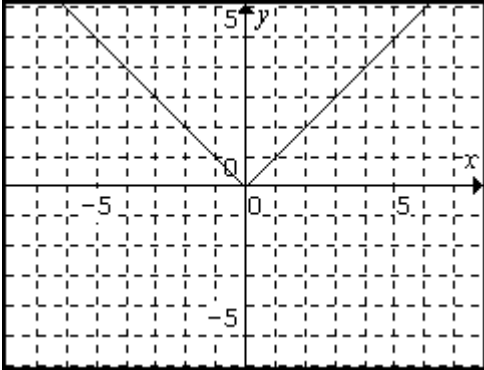

reflection about y-axis (no effect on graph)

11.

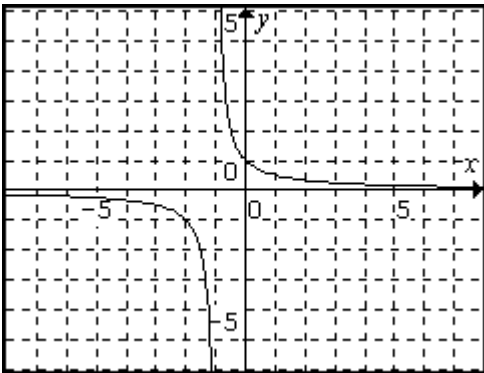

Shift left 1 unit

13.

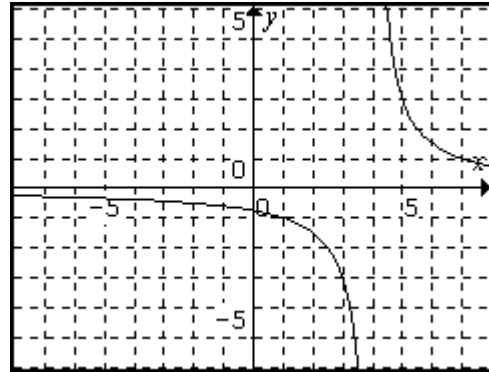

Shift 4 units right

15.

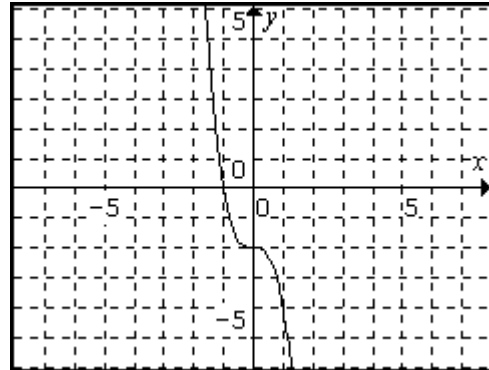

Reflect about x-axis

Shift down 2 units

17.

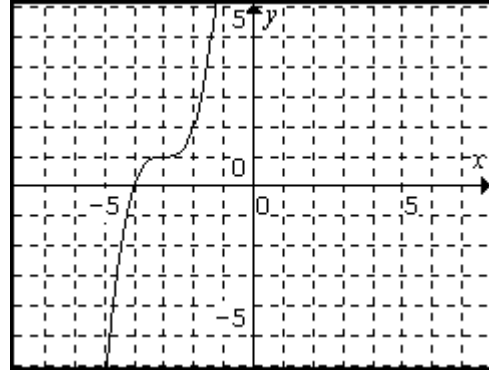

Shift left 3 units

Shift up 1 unit

19.

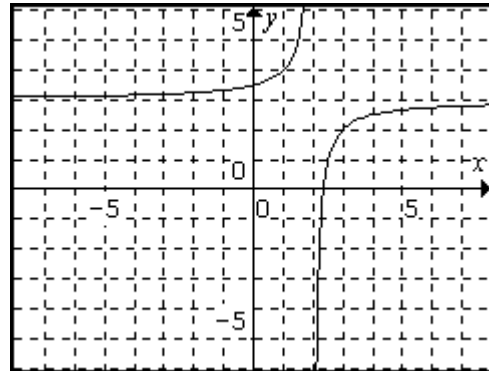

Reflection about x-axis

Shift right 2 units, up 3 units

21.

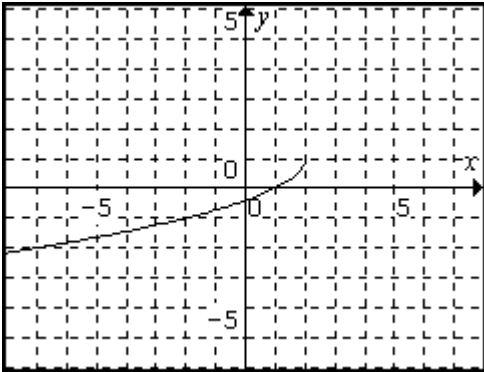

Reflect about the x-axis
Reflect about the y-axis
Shift right 2 units
Shift 1 unit up

23.

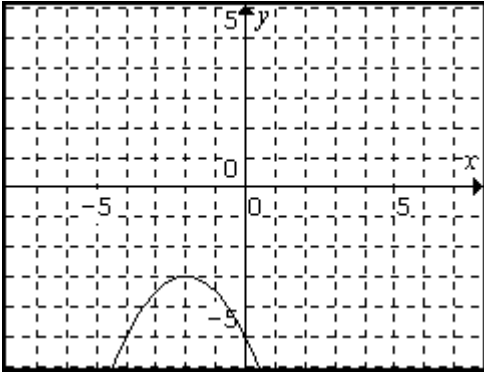

Reflect about x-axis
Shift left 2 units
Shift down 3 units

25.

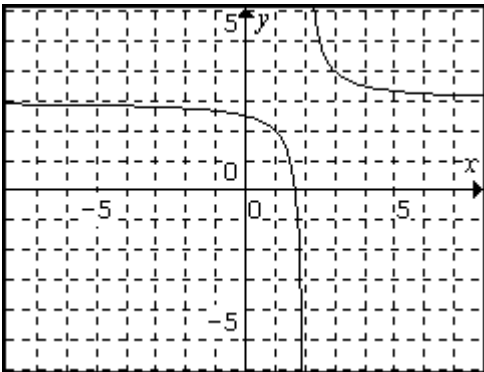

Shift Right 2 units
Shift up 3 units

27.

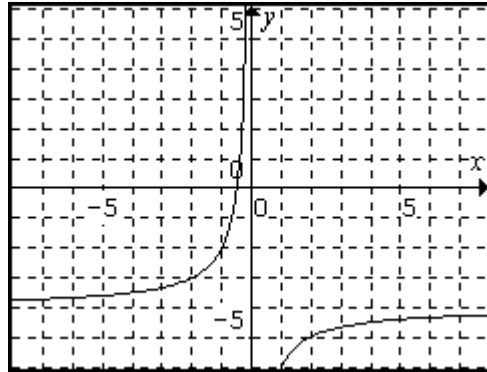

Reflection about x-axis
Shift down 4 units

29.

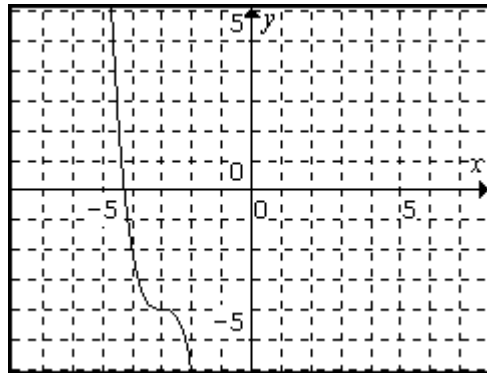

Reflection about x-axis
Left 3 units
Down 4 units

31.

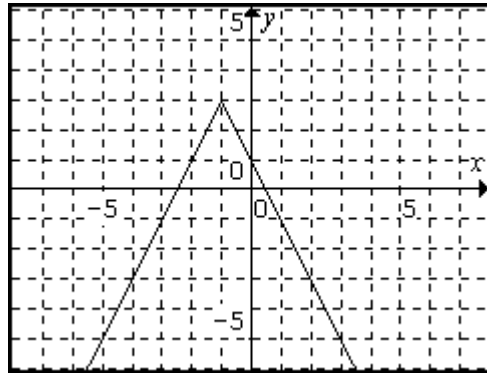

Reflection about x-axis
Shift left 1 unit
Shift up 3 units

33.

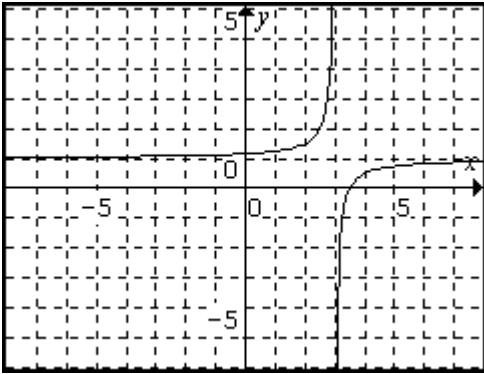

Reflection about x-axis
 Shift right 3 units
 Shift up 1 unit

35.

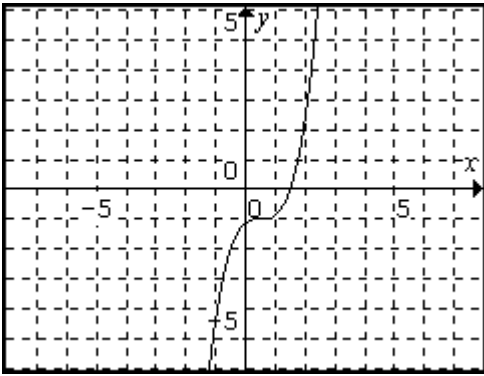

Shift right $\frac{1}{2}$ Unit
 Shift down 1 unit

37.

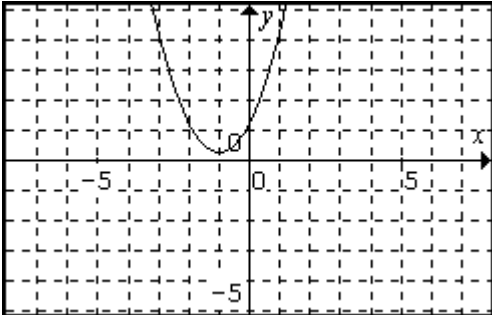

Shift left 1 unit
 Shift up $\frac{1}{4}$ unit

39.

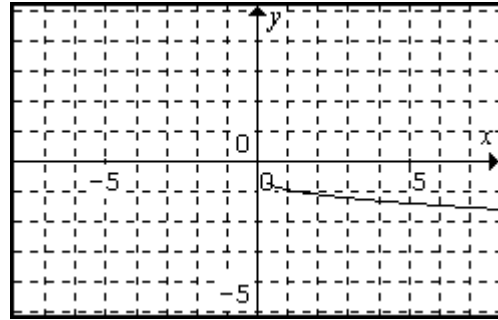

Reflection about x-axis

Shift right $\frac{1}{3}$ unit

Shift down $\frac{2}{3}$ unit

41.

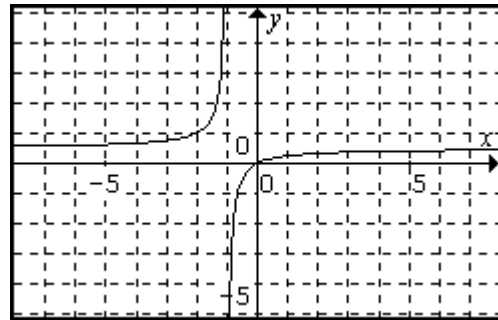

Reflection about x-axis

Shift 1 unit left

Shift up $\frac{1}{2}$ unit

43. a.

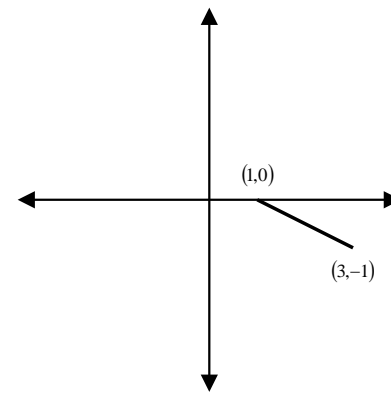

b.

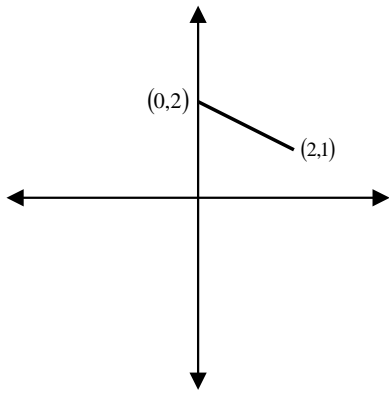

c.

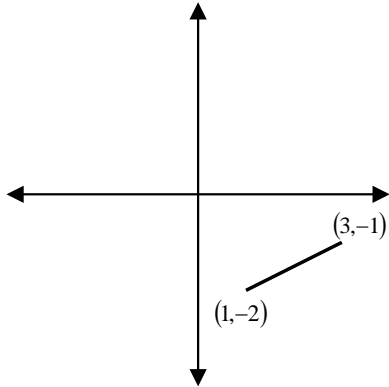

d.

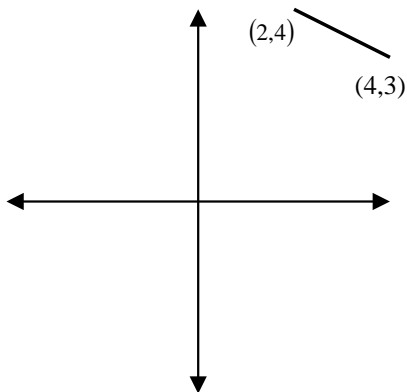

45. a.

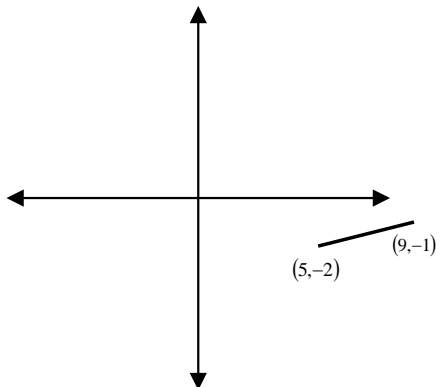

b.

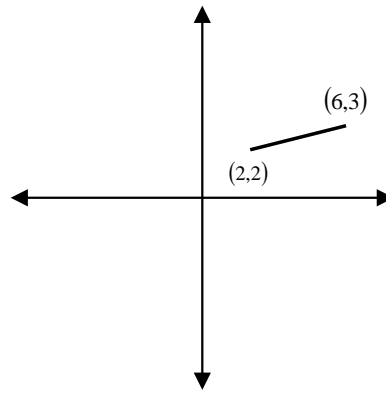

c.

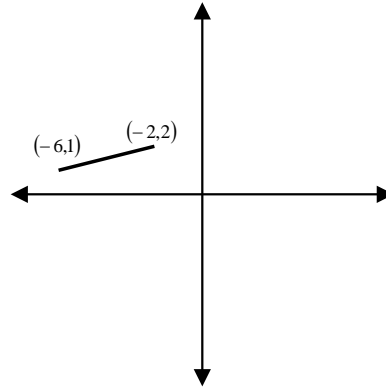

d.

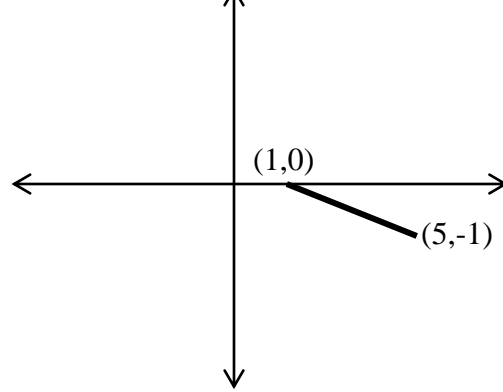

49. $f(x) = |-(x-2)|$

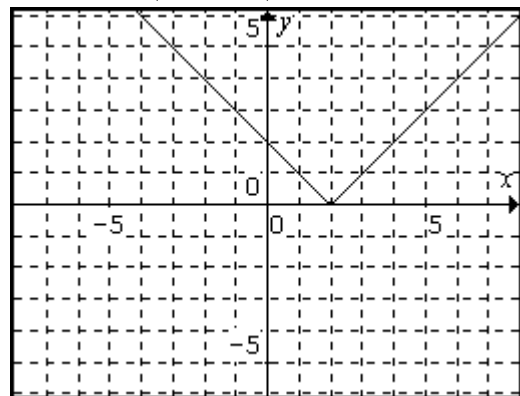

$$51. g(x) = -\frac{1}{x-1}$$

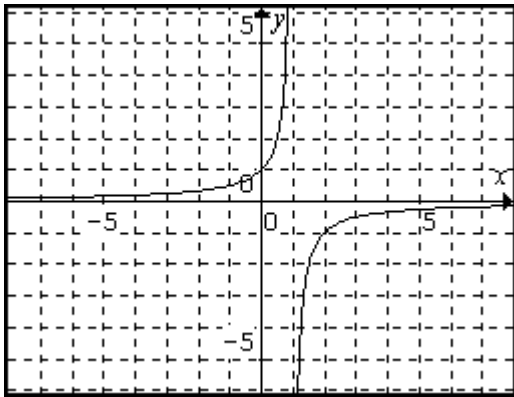

$$53. h(x) = 1 - \sqrt{-(x-1)}$$

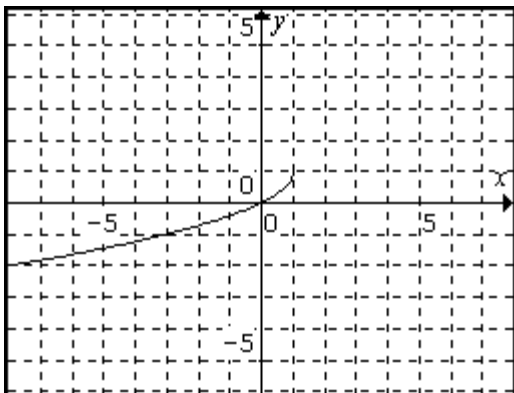

$$55. f(x) = 2\sqrt{-(x-1)} + 1$$

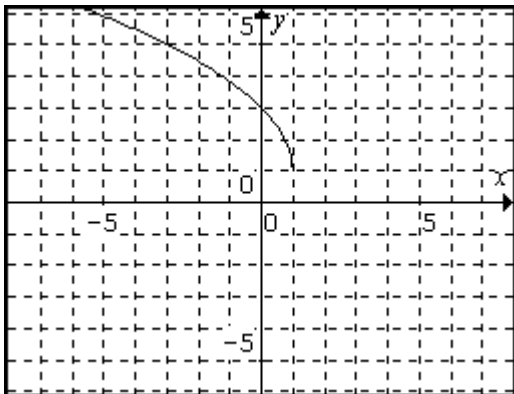

$$57. f(x) = \frac{1}{2}(-(x-2))^2 - 1$$

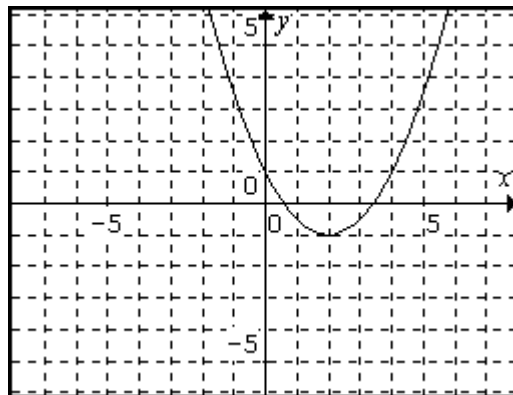

$$59. f(x) = 2 - 3(-(x-3))^3$$

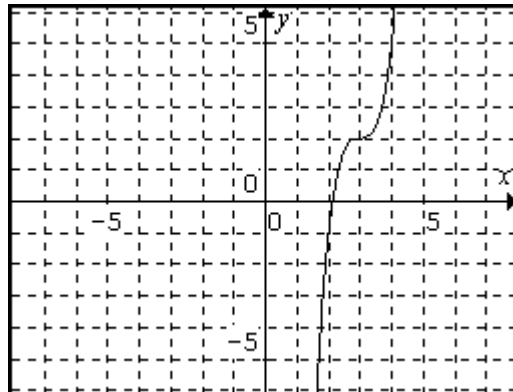

Section 9.5

1. 1

7. $-a^2 + 4a - 2ah + 4h - h^2 - 2$

13. $\frac{x}{(x+1)^2}$

19. x

3. $x^2 - 4x + 2$

9. $\frac{2ab-1}{a^2b^2-2ab+1}$

15. $\frac{x-1}{x+1}$

21. $\sqrt{x-1} + x^2 + 1$

5. -1

11. 1

17. $\frac{a-2}{a}$

23. $\frac{-x^3 - x + 2}{x}$

25. $\frac{2x^2 + 2}{x}$

31. 22

37. $6x^2 - 3x + 13$

43. 2

49. x

55. $\sqrt{|2t-1|+1}$

59. $a^4 - 4a^3b + 6a^2b^2 - 4a^2 - 4ab^3 + 8ab + b^4 - 4b^2 + 2$

61. $x+h-1$

67. $\sqrt{x^2-1}$

27. $(x^2+1)\sqrt{x-1}$

33. 95

39. $9x+4$

45. 2

51. $\sqrt{3}$

57. $a+7$

63. $x-1$

69. $x^4 - 4x^2 + 2$

29. $\frac{x^3+x}{2}$

35. 121

41. $\frac{1}{2}$

47. $\frac{x}{x+2}$

53. 3

65. $4x^2 - 4x - 1$

Section 9.6

$7a+4=7b+4$

1. $7a=7b$
 $a=b$

$\frac{1}{3}a + \frac{1}{4} = \frac{1}{3}b + \frac{1}{4}$

3. $\frac{1}{3}a = \frac{1}{3}b$
 $a=b$

$\sqrt{a-1} = \sqrt{b-1}$

5. $a-1=b-1$
 $a=b$

$2\sqrt[3]{a} = 2\sqrt[3]{b}$

7. $\sqrt[3]{a} = \sqrt[3]{b}$
 $a=b$

$\frac{1}{a+1} = \frac{1}{b+1}$

9. $b+1=a+1$
 $b=a$

11. No

13. Yes

15. No

17. $(f \circ g)(x) = x, (g \circ f)(x) = x$

19. $(f \circ g)(x) = x, (g \circ f)(x) = x$

21. $(f \circ g)(x) = x, (g \circ f)(x) = x$

23. $(f \circ g)(x) = x, (g \circ f)(x) = x$

25. $(f \circ g)(x) = x, (g \circ f)(x) = x$

27. $(f \circ g)(x) = x, (g \circ f)(x) = x$

29. $(f \circ g)(x) = x, (g \circ f)(x) = x$

31. $f^{-1}(x) = \frac{x-4}{7}$

33. $f^{-1}(x) = 3x - \frac{3}{4}$

35. $f^{-1}(x) = -4x + 2$

37. $g^{-1}(x) = x^2$

39. $g^{-1}(x) = -x^3 + 2$

41. $g^{-1}(x) = \sqrt[3]{x-4}$

43. $g^{-1}(x) = \sqrt{\frac{x-4}{2}}$

45. $h^{-1}(x) = \frac{1}{x}$

47. $h^{-1}(x) = \frac{1}{x} - 1$

49. $h^{-1}(x) = \frac{1}{x-3} + 1$

51. $f^{-1}(x) = \frac{(x-2)^3 + 3}{2}$

53. $f^{-1}(x) = \frac{-2x}{2-x}$

55. $g^{-1}(x) = \frac{-x-1}{x-1}$

57. $h^{-1}(x) = \sqrt[4]{\frac{x-8}{7}}$

59. $f^{-1}(x) = \frac{(x+1)^2}{4} - 1$

61. $f^{-1}(x) = \sqrt[3]{x^3 + 2}$

63. $f^{-1}(x) = \sqrt{\frac{1}{x+2}}$

65. $h^{-1}(x) = \frac{1}{(x-2)^3}$

67.

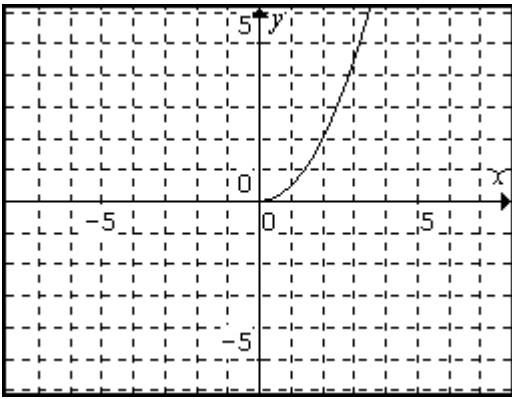

69.

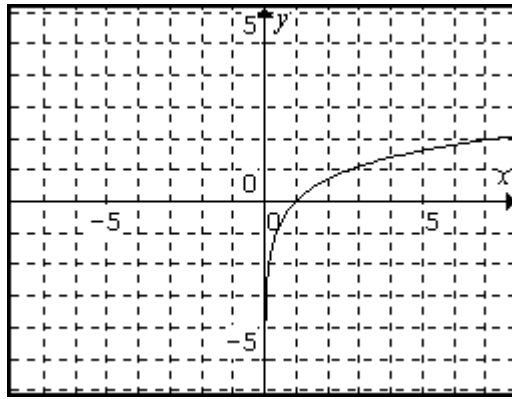

71.

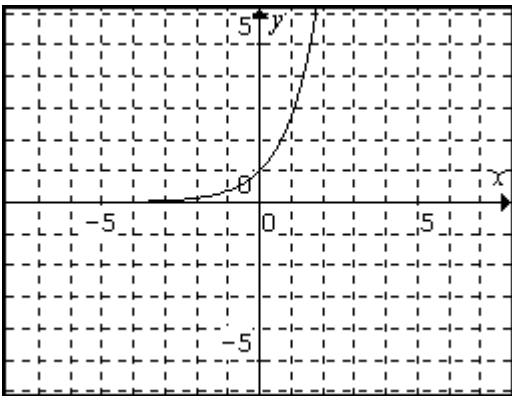

73.

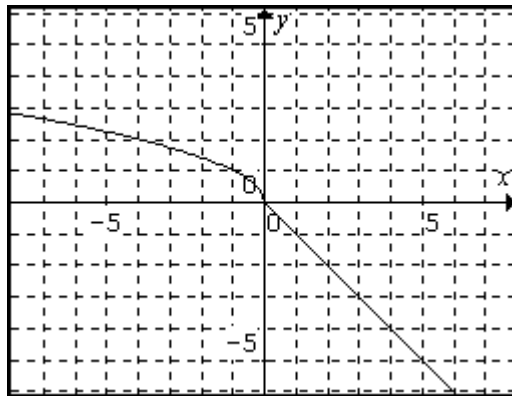

75. $f^{-1}(x) = (x-1)^2$ $D: [1, \infty)$

77. $f^{-1}(x) = x^2 - 1$ $D: [0, \infty)$

79. $f^{-1}(x) = -x^4 + 2$ $D: [0, \infty)$

81. $f^{-1}(x) = \sqrt{x-1}$ 83. $f^{-1}(x) = -\sqrt{x} - 2$

Section 9.7

1. \$30; \$50

3. \$3250; 6 computers

5. 85.73 board feet; 166.69 board feet

7. 6 teams; 45 games

9. 2 seconds

11. 9.7-ft; 67.2-ft

13. 1.11 sec; 3.24-ft

15. \$50; \$480; Yes

17. $A(w) = 2w^2 + 3w$; 14 m^2 ; 3m by 9m19. $A(l) = l^2 - l$; 90 sq ft; 5 ft by 4 ft

21. $A(b) = \frac{3b^2 + 2b}{2}$; 42.5 sq yd; base 4 yd, height 14 yd

23. $V(S) = \frac{\sqrt{\pi^3 S^3}}{6\pi^2}$; $\frac{2}{3}$

25. $A(w) = 25w - w^2$; 66 sq yd; 2 yd by 23 yd.

27. $A(C) = \frac{C^2}{4\pi}$; $\frac{64}{\pi} \approx 20.4 - yd^2$; $C = \frac{1}{2} yd$

29. $A(l) = \frac{l^2}{4\pi}$; $\frac{4}{\pi} \approx 1.27 - in^2$; 1 in

31. $A(x) = \frac{500x - x^2}{2}$; 31250 sq ft; impossible

33. $A(x) = \frac{400x - 3x^2}{2}$; 10650 sq ft; shorter side 20 ft, longer side 170 ft

35. $A(x) = 50x - 2x^2$; 252 sq yd; longer side of 20 yd shorter side of 10 yd

37. 3 cm

39. 23.75 lbs

41. 25.3 lbs/in²

43. 6.4 ft

45. 2.6 in

47. 675 units

49. 6.4 hrs

51. 4 in

53. 146.7 lbs

55. 30 amps

57. 2250 lbs

59. 9.75 cm

61. 10 ft/sec